

EBONITE VANTECH™

Assembly Instruction – 8 Ft Divider with Ball Racks and Coat Rack 30-5203

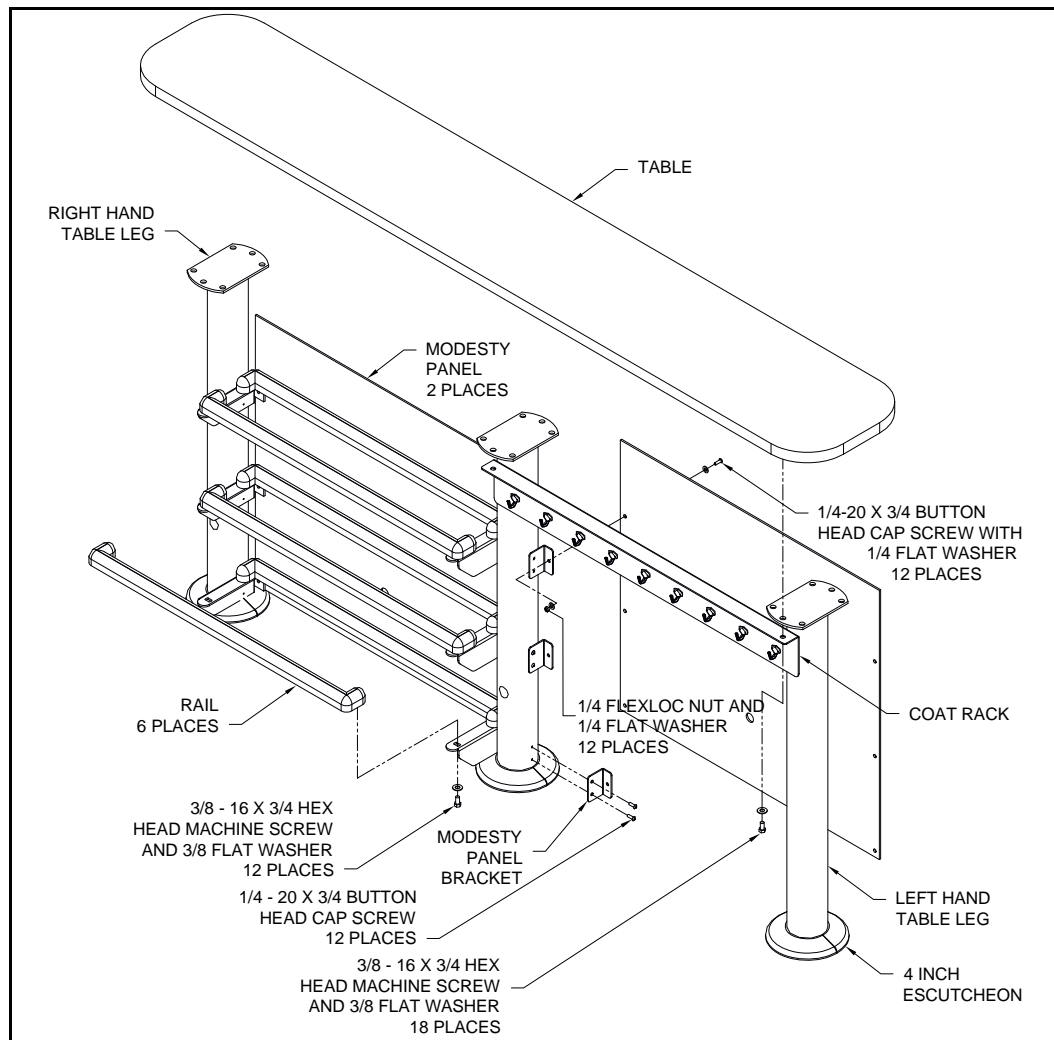

Assembly Exploded View

Tool List

3/8" drive Socket Wrench

Hex Socket – 1/2", 9/16"

Allen Wrench – 5/32"

Table Assembly

Use the Assembly Exploded View drawing as a guide while performing the following instructions.

Some steps of this assembly process are easier when two people are available.

Finger tight means snug and then back out ¼ turn.

1. Place the table top upside down on a piece of cushioning material (like the box it came in).
2. Stand the table legs on the bottom of the table over their mounting holes.
3. Insert the 6 screws through the mounting flange on each leg and tighten finger tight.
4. Mount the 6 Ball Racks and tighten the screws finger tight.
5. Mount the 6 Modesty Panel Brackets as shown. Leave the screws finger tight.
6. Mount the 2 Modesty Panels. Tighten the hardware finger tight.
7. Now, tighten the screws holding the legs to the table. Next, tighten the screws holding the Modesty Panels to their brackets, then the 6 Modesty Panel Mounting Brackets.
8. Tighten the screws holding the Ball Racks.
9. Holes are provided on the flanges at the bottom of the table legs. You must attach the unit to the floor using these holes and hardware appropriate for your type of floor.
10. After bolting the unit to the floor, twist the Escutcheons and place them around the legs. Push them down to cover the flanges.

